

LOC	DIST	REVISIONS			
		REV	DATE	BY	CHK
AA	00	E	13APR2011	RG	MS
		E1	30SEP2011	RG	RP
		E2	03NOV2011	OL	SZ
		E4	08JAN2015	SZ	SZ

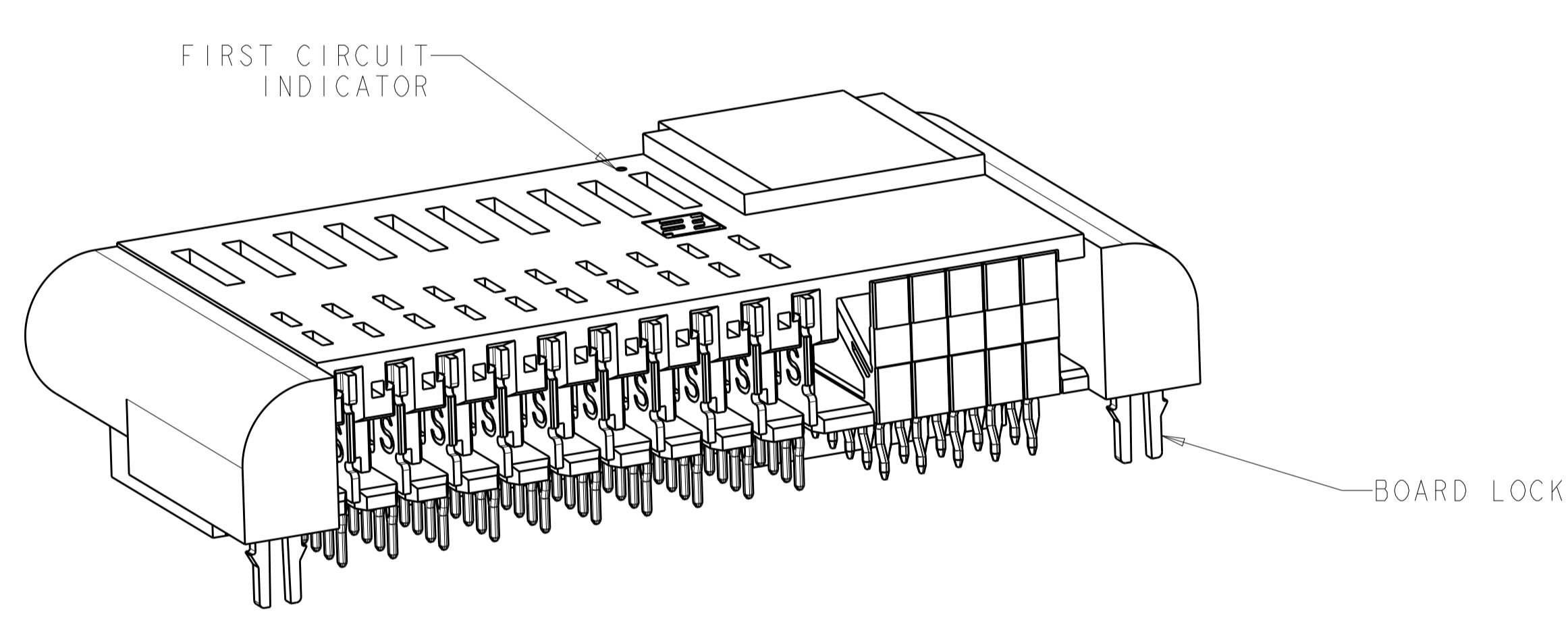
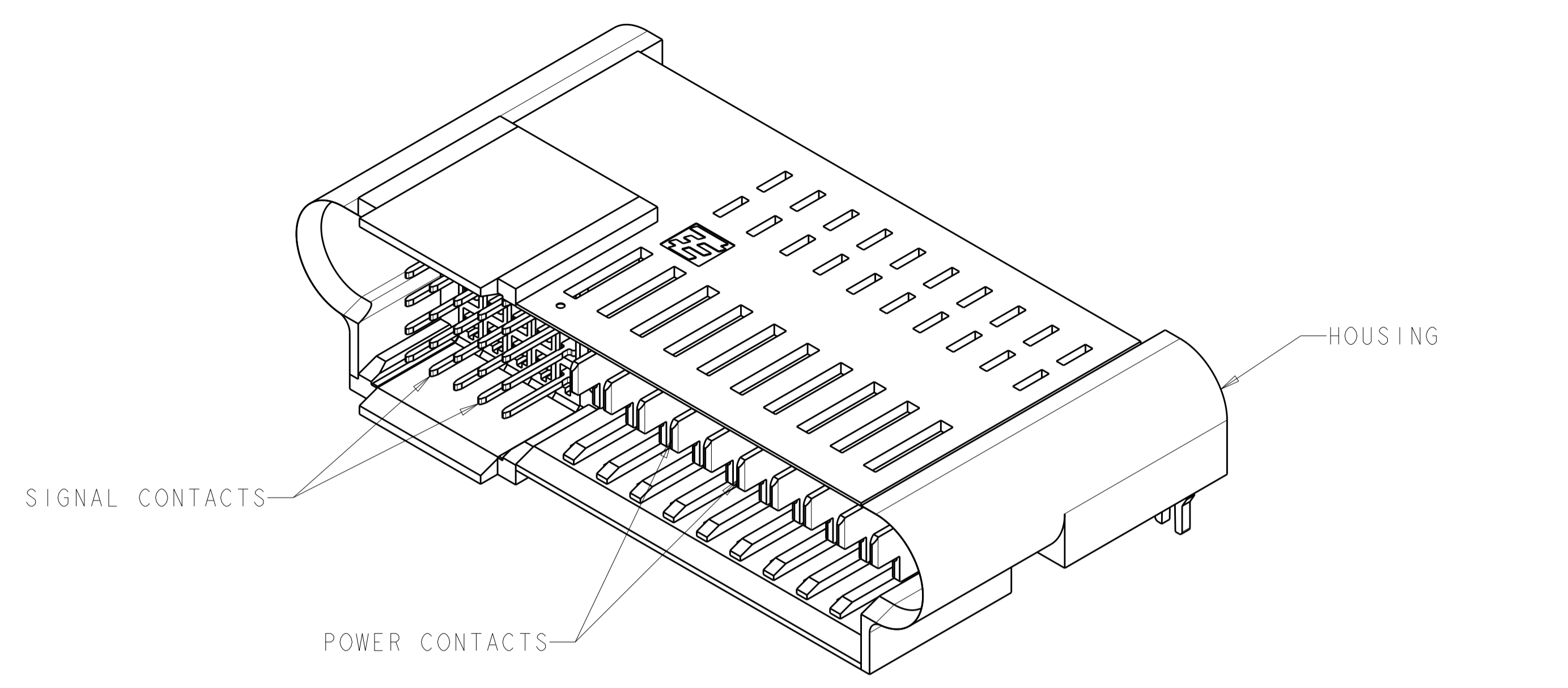

2-1926730-5 SHOWN

- HOUSING: GLASS FILLED LIQUID CRYSTAL POLYMER, COLOR: BLACK, UL 94 V-O RATED
 SIGNAL CONTACT: PHOSPHOR BRONZE
 SIGNAL OVERMOLD: GLASS FILLED POLYESTER
 POWER CONTACT: COPPER ALLOY
 BOARD LOCKS: PHOSPHOR BRONZE
 - SIGNAL CONTACT: 0.00127mm MIN NICKEL ALL OVER,
 MATING AREA: 0.00076mm MIN GOLD OR 0.00008mm MIN GOLD OVER
 0.00076mm MIN PALLADIUM-NICKEL
 TAIL AREA: 0.0005mm MIN MATTE TIN
 POWER CONTACT: 0.00127mm MIN NICKEL ALL OVER,
 MATING AREA: 0.00076mm MIN GOLD OR
 0.00008mm MIN GOLD OVER 0.00076mm MIN PALLADIUM-NICKEL,
 TAIL AREA: 0.0005mm MIN MATTE TIN
 BOARD LOCKS: 0.00076mm MIN MATTE TIN OVER
 0.00127mm MIN NICKEL.
 - CONTACT MATING AREA LUBRICATED WITH BELLCORE APPROVED LUBRICANT,
 TECHNICAL REFERENCE: GR-1217-CORE, ISSUE 1, NOVEMBER 1995.
 - THIS CONNECTOR EMPLOYS UL RECOGNIZED Z-PACK 2mm HM SIGNAL CONTACTS
- △ DATUMS AND BASIC DIMENSIONS TO BE ESTABLISHED BY CUSTOMER.
- △ PC BOARD THICKNESS 1.4mm MIN, FOR WAVE SOLDER PC BOARD THICKNESS 2.62 MAX
- △ SEE APPLICATION SPEC 114-13215 FOR PLATED THROUGH HOLE INFORMATION
8. SEE CUSTOMER DRAWING 1926731 OR 1926733 FOR MATING CONNECTOR
- △ UNPLATED HOLES

12	15	1	2	20.60	25.71	15S X 2P	8-1926730-0
12	10	1	1	18.60	23.71	10S X 2P	7-1926730-9
36	20	5	3	33.60	38.71	20S X 6P	1-1926730-0
144	40	23	10	91.10	96.21	40S X 24P	7-1926730-7
96	25	15	4	63.10	68.21	25S X 16P	4-1926730-6
72	15	11	2	48.10	53.21	15S X 12P	3-1926730-0
60	25	9	4	46.60	51.71	25S X 10P	2-1926730-5
48	25	7	4	41.10	46.21	25S X 8P	1-1926730-8
24	10	3	1	24.10	29.21	10S X 4P	1926730-1
DIM F	DIM E	DIM D	DIM C	DIM B	DIM A	NUMBER OF POSITIONS	PART NUMBER

DIMENSIONS: mm TOLERANCES UNLESS OTHERWISE SPECIFIED: 0 PLC ± 1 PLC ±0.13 2 PLC ± 3 PLC ± 4 PLC ± ANGLES ± FINISH SEE NOTE 2		DWN G. PETERS 19OCT2007 CHK N. REESER 11APR2008 APVD N. REESER 11APR2008 PRODUCT SPEC 108-2325 APPLICATION SPEC 114-13215 WEIGHT - CUSTOMER DRAWING	Tyco Electronics Harrisburg, PA 17105-3608 NAME PLUG ASSEMBLY, RIGHT ANGLE, PASSIVE GUIDE, SIGNAL/POWER, WITH BOARD LOCKS, MINIPAK HDL SIZE CAGE CODE DRAWING NO A100779C=1926730 SCALE 4:1 SHEET 1 OF 3 REV E4
--	--	---	---

LOC	DIST	REVISIONS					
		P.	LTN	DESCRIPTION	DATE	DWN	APVD
AA	00	-	-	SEE SHEET 1	-	-	-

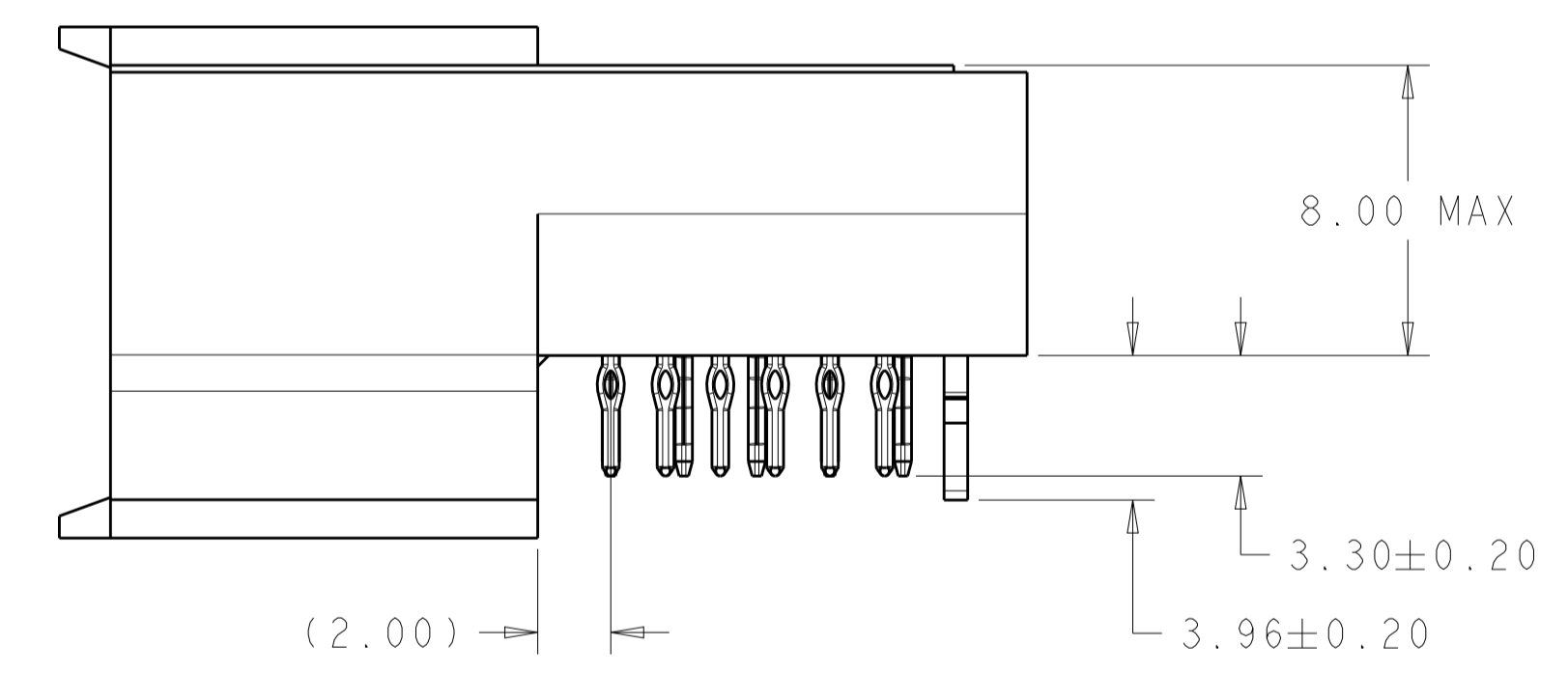
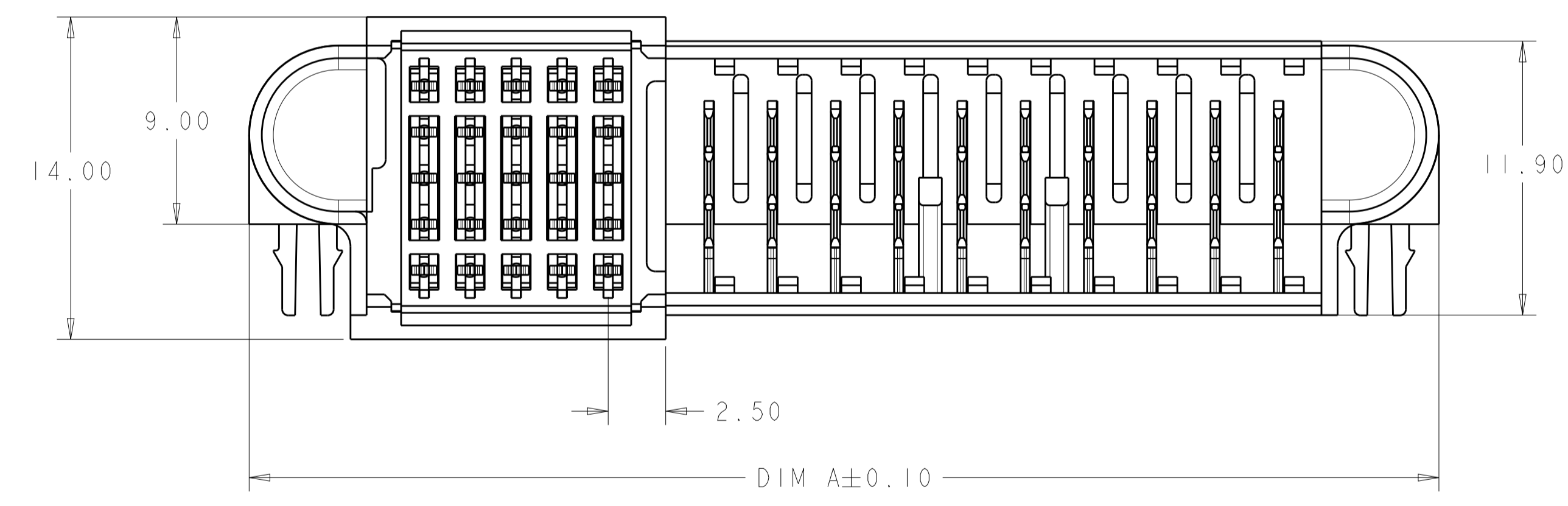
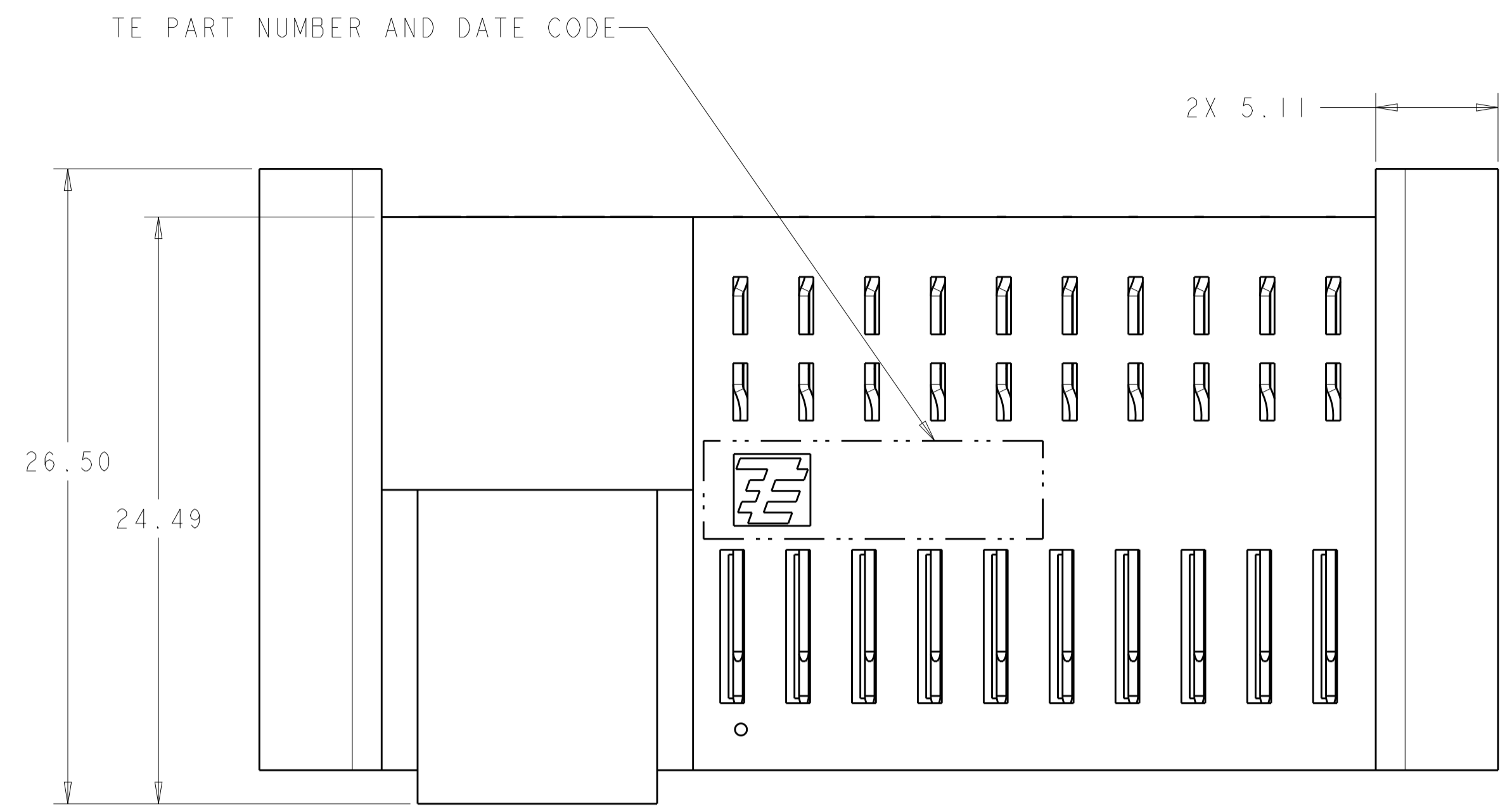

<small>THIS DRAWING IS UNPUBLISHED. RELEASED FOR PUBLICATION BY TYCO ELECTRONICS CORPORATION. ALL RIGHTS RESERVED.</small>		DWN G. PETERS 19OCT2007 CHK N. REESER 11APR2008 APVD N. REESER 11APR2008	Tyco Electronics Harrisburg, PA 17105-3608
DIMENSIONS: mm 	TOLERANCES UNLESS OTHERWISE SPECIFIED: 0 PLC ± 1 PLC ±0.13 2 PLC ± 3 PLC ± 4 PLC ± ANGLES ±	NAME PRODUCT SPEC APPLICATION SPEC SIZE WEIGHT	NAME PLUG ASSEMBLY, RIGHT ANGLE, PASSIVE GUIDE, SIGNAL/POWER, WITH BOARD LOCKS, MINIPAK HDL SIZE CAGE CODE DRAWING NO RESTRICTED TO
MATERIAL SEE NOTE 1	FINISH SEE NOTE 2	WEIGHT CUSTOMER DRAWING	A 100779 C=1926730 SCALE 4:1 SHEET 2 OF 3 REV E.4

LOC		DIST		REVISIONS			
AA	00	P	LTH	DESCRIPTION	DATE	OWN	APVD
		-		SEE SHEET 1			

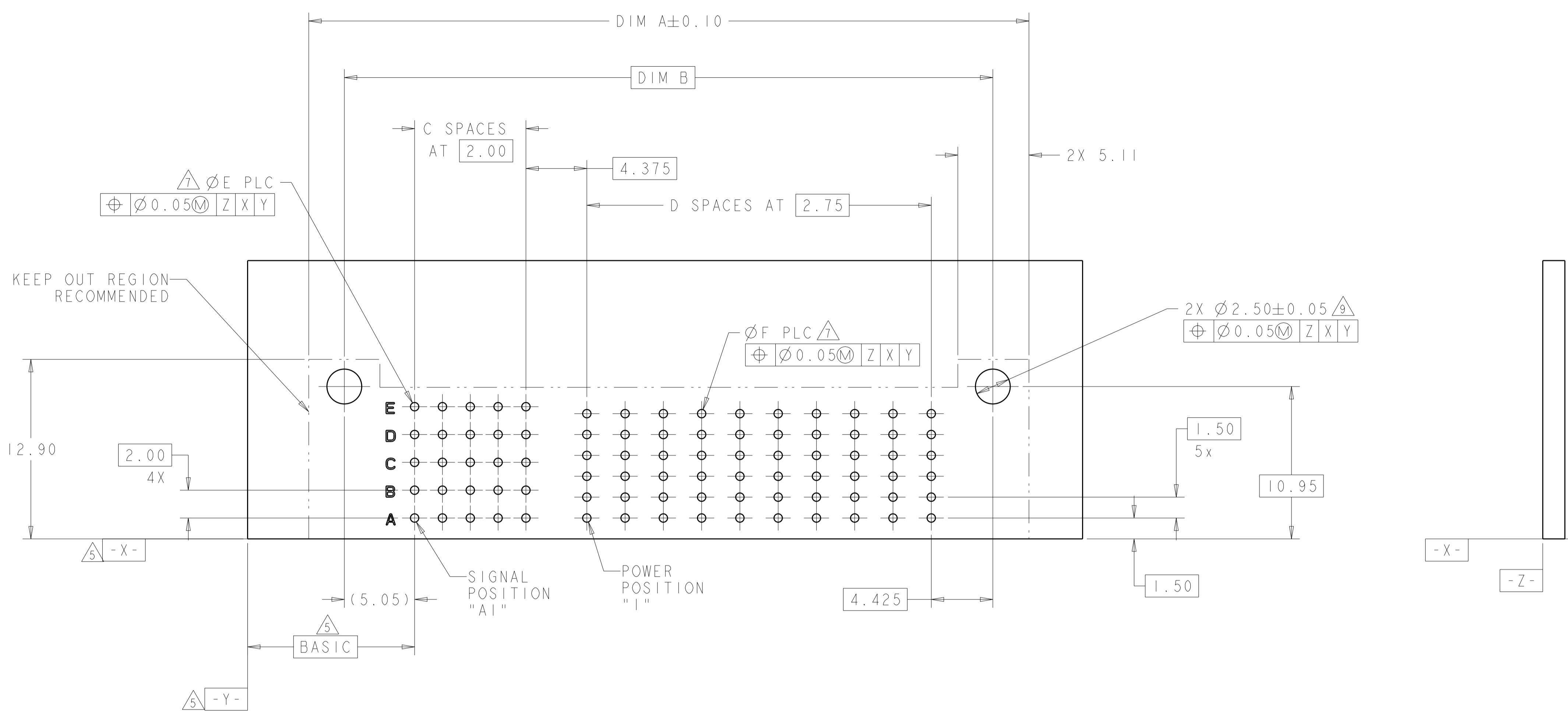

2-1926730-5 SHOWN
RECOMMENDED PRINTED CIRCUIT BOARD LAYOUT
 (AS VIEWED FROM COMPONENT SIDE)

<small>THIS DRAWING IS UNPUBLISHED. IT IS THE PROPERTY OF TYCO ELECTRONICS CORPORATION. IT IS SUBJECT TO CHANGE AND WITHOUT WARRANTY. REVISIONS SHOULD BE CONTACTED FOR THE LATEST REVISION.</small>		DWN: G. PETERS 19OCT2007 CHK: N. REESER 11APR2008 APVD: N. REESER 11APR2008	Tyco Electronics Harrisburg, PA 17105-3608
DIMENSIONS: mm 	TOLERANCES UNLESS OTHERWISE SPECIFIED: 0 PLC ± 1 PLC ±0.13 2 PLC ± 3 PLC ± 4 PLC ± ANGLES ±	NAME: PLUG ASSEMBLY, RIGHT ANGLE, PASSIVE GUIDE, SIGNAL/POWER, WITH BOARD LOCKS, MINIPAK HDL PRODUCT SPEC: 108-2325 APPLICATION SPEC: 114-13215 WEIGHT: -	SIZE: A CAGE CODE: 00779 DRAWING NO: 1926730 RESTRICTED TO: -
MATERIAL: SEE NOTE 1	FINISH: SEE NOTE 2	CUSTOMER DRAWING	SCALE: 4:1 SHEET 3 OF 3 REV: E4